

A *Nidec* Group Company

COPAL

All for dreams

High Security and Sophisticated Laser Personalization System

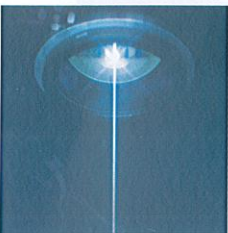

- All-in-one compact desktop body.
- Hardware Key Locks on all card stackers.
- Eco-Friendly. Low Power Consumption 350VA.
- High Safety Standard. IEC 60825-1 standards Class 1 Laser Product.
- High Throughput.
- Modular Component Design for quick & easy maintenance.

Laser Maker for ID Card

CLM-50

MADE IN JAPAN



Desktop Laser Personalization System for ID Card

CLM-50



Specifications

| | |
|---------------------------------|--|
| Card format | ISO/IEC 7810 ID-1 |
| Card material | Polycarbonate, PET-G, ABS, PVC (Cards for Laser) |
| Automatic Card Dispenser | 350 Cards |
| Smart Card | Contact: ISO/IEC 7816-3 / Contactless: ISO14443 |
| Camera (for XY adjust) | 350dpi (0.073mm/pixel) |
| Laser Light Source | Air Cooled Fiber Laser (10W) |
| Marking Items | Text / Barcode (PDF417, Code128, etc) / Image (JPG, BMP with Gray Scale) |
| Marking Side | Both (with Flipper) |
| MLI | 25 deg. Glass Prism (Built-in Option) |
| CLI | 25 deg. Glass Prism (Built-in Option) |
| Reject Stacker | 20 Cards |
| Output Stacker | 100 Cards |
| Power Supply | AC100-240V, 50/60Hz 350VA |
| Interface | USB2.0, Ethernet LAN |
| Operating System | Windows® 7(32/64Bit), Windows® 8 |
| Dimensions | 572mm(W) x 515mm(D) x 560mm(H) |
| Weight | 68kg |

Dimensions (mm)

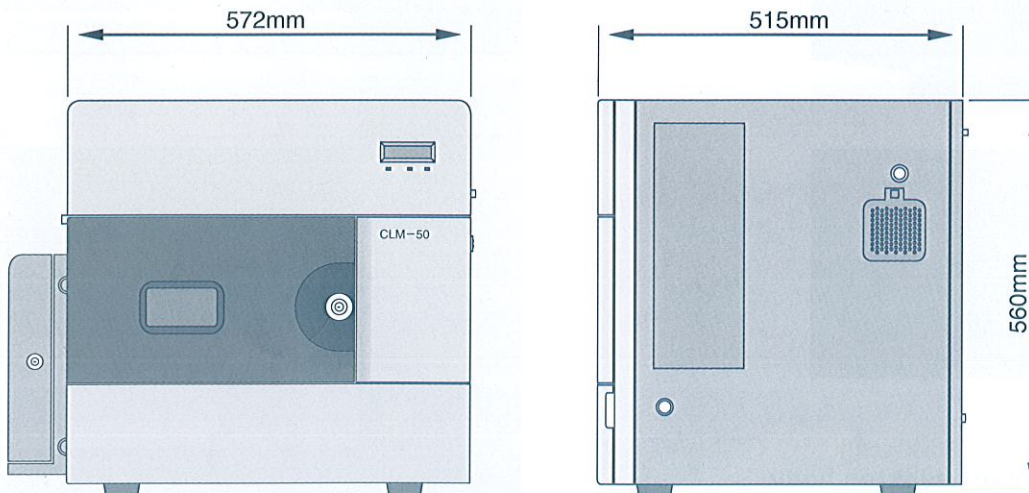

NIDEC COPAL CORPORATION

International Sales Department

2-18-10, Shimura, Itabashi-Ku, Tokyo, 174-8550, JAPAN

Phone: +81-3-3965-1264 Fax: +81-3-3965-1266 Contact: lasersystem@nidec-copal.com

URL: <http://www.nidec-copal.com/>

●Microsoft and Windows are registered trademarks of Microsoft Corporation in the United States and other countries. ●Specifications and features are subject to change without prior notice.



Please read the instruction manual before starting to use CLM-50 in order to make sure the correct and safe use of the product.